

No. 36
2023
web

NITTO



Track Racing



approved by "KEIRIN"
Professional Races in Japan
本品はJKAの競走車部品
適合認定品です



B123 Steel

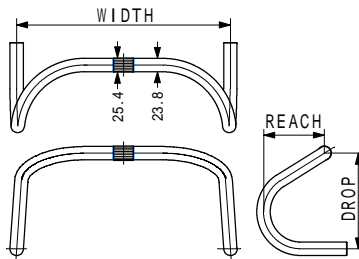

MATERIAL / STEEL TUBE
CENTER DIAM / 25.4
BAR DIAM / 23.8
COLOR / SILVER

MODEL	WIDTH	DROP	REACH	WEIGHT
B123-34	340	170	108	700 g
B123-35	350			710 g
B123-36	360			720 g
B123-37	370			730 g
B123-38	380			740 g
B123-39	390			750 g
B123-40	400			760 g



B123AA

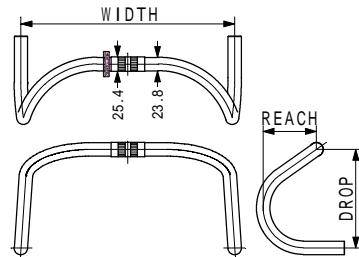

MATERIAL / HEAT TREATED ALUMINUM
CENTER DIAM / 25.4
BAR DIAM / 23.8
COLOR / SILVER ANODIZED

MODEL	WIDTH	DROP	REACH	WEIGHT
B123AA-35	350	175	95	325 g
B123AA-36	360			330 g
B123AA-37	370			335 g
B123AA-38	380			340 g
B123AA-39	390			345 g
B123AA-40	400			350 g



B123Cr.Mo.

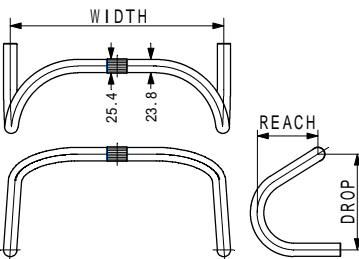

MATERIAL / CrMo STEEL TUBE
CENTER DIAM / 25.4
BAR DIAM / 23.8
COLOR / SILVER

MODEL	WIDTH	DROP	REACH	WEIGHT
B123CrMo-34	340	170	108	665 g
B123CrMo-35	350			675 g
B123CrMo-36	360			685 g
B123CrMo-37	370			695 g
B123CrMo-38	380			705 g
B123CrMo-39	390			715 g
B123CrMo-40	400			725 g
B123CrMo-41	410			735 g
B123CrMo-42	420			745 g



B125 Steel

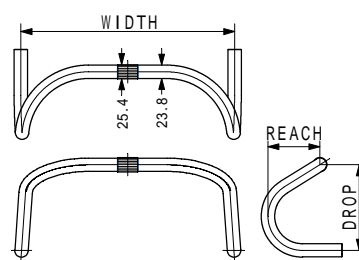

MATERIAL / STEEL TUBE
CENTER DIAM / 25.4
BAR DIAM / 23.8
COLOR / SILVER

MODEL	WIDTH	DROP	REACH	WEIGHT
B125-36	360	152	92	660 g
B125-37	370			670 g
B125-38	380			680 g
B125-39	390			690 g
B125-40	400			700 g
B125-41	410			710 g
B125-42	420			720 g



B125AA

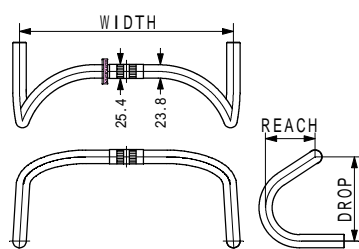

MATERIAL / HEAT TREATED ALUMINUM
CENTER DIAM / 25.4
BAR DIAM / 23.8
COLOR / SILVER ANODIZED

MODEL	WIDTH	DROP	REACH	WEIGHT
B125AA-35	350	150	88	305 g
B125AA-36	360			310 g
B125AA-37	370			315 g
B125AA-38	380			320 g
B125AA-39	390			325 g
B125AA-40	400			330 g

Track Racing



N.J.PRO AA

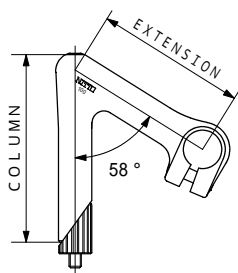

MATERIAL / FORGED ALUMINUM
 BAR CLAMP / 25.4mm
 POST DIAM / 22.2mm
 COLOR / SILVER ANODIZED

MODEL	EXTENSION	COLUMN	WEIGHT
N.J.PRO AA 80	80	125	280g
N.J.PRO AA 90	90		290g
N.J.PRO AA 100	100		300g
N.J.PRO AA 110	110		310g
N.J.PRO AA 120	120		320g



N.J.PRO 58°/65°

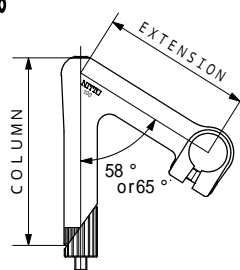

MATERIAL / FORGED STEEL
 BAR CLAMP / 25.4mm
 POST DIAM / 22.2mm
 COLOR / SILVER

MODEL	EXTENSION	COLUMN	WEIGHT
N.J.PRO 70	70	125	365g
N.J.PRO 75	75		373g
N.J.PRO 80	80		380g
N.J.PRO 85	85		388g
N.J.PRO 90	90		395g
N.J.PRO 95	95		402g
N.J.PRO 100	100		410g
N.J.PRO 105	105		418g
N.J.PRO 110	110		426g
N.J.PRO 115	115		434g
N.J.PRO 120	120		442g
N.J.PRO 125	125		450g
N.J.PRO 130	130		458g
N.J.PRO 135	135		467g
N.J.PRO 140	140	475g	



NP

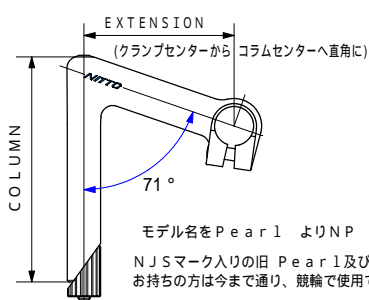

モデル名を Pearl より NP に変更いたします。
 NJSマーク入りの旧 Pearl 及び Pearl を、
 お持ちの方は今まで通り、競輪で使用できます。

MODEL	EXTENSION	COLUMN	WEIGHT
NP 8	80	150	300g
NP 9	90		315g
NP 10	100		330g
NP 11	110		345g
NP 12	120		360g

MATERIAL / FORGED ALUMINUM
 BAR CLAMP / 25.4mm
 POST DIAM / 22.2mm
 COLOR / SILVER ANODIZED

NJ-89



NJS girls keirin stem

MATERIAL / FORGED ALUMINUM
 BAR CLAMP / 25.4mm
 POST CLAMP / 28.6mm
 ANGLE / 73°
 COLOR / SILVER ANODIZED



MODEL	EXTENSION	WEIGHT
NJ-89 60	60	140g
NJ-89 70	70	144g
NJ-89 80	80	148g
NJ-89 90	90	152g
NJ-89 100	100	156g
NJ-89 110	110	160g
NJ-89 120	120	164g

for B123AA, B125AA
 適用ハンドルバー B123AA, B125AA

TRACK RACING SEAT POST

Two-Bolt type, tighten from bottom of the clamp.

トラックレース用 シートピラー
 2本のボルトで下から締める構造



NJ·SP72-W44

MATERIAL / FORGED ALUMINUM
 POST DIAM / 27.2
 / 27.0
 / 26.8
 LENGTH / 210, 250mm
 SADDLE RAIL WIDTH / 44mm
 OFFSET / 22mm
 WEIGHT / 270, 290g
 COLOR / SILVER ANODIZED



NJ·SP72-W30

MATERIAL / FORGED ALUMINUM
 POST DIAM / 27.2
 / 27.0
 / 26.8
 LENGTH / 210, 250mm
 SADDLE RAIL WIDTH / 30mm
 OFFSET / 22mm
 WEIGHT / 245, 265g
 COLOR / SILVER ANODIZED





Track Racing PIST6 RACE 250 Over sized

B123CrMo-SSB

MATERIAL / CrMo STEEL TUBE
 CENTER DIA / 31.8
 BAR DIA / 23.8
 COLOR / SILVER

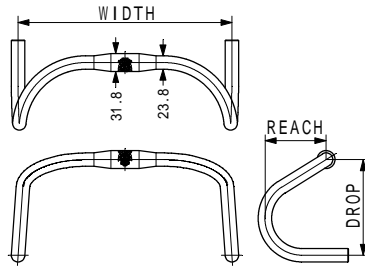

MODEL	WIDTH	DROP	REACH	WEIGHT
B123CrMo-SSB 370	370	170	108	560 g
B123CrMo-SSB 380	380			570 g
B123CrMo-SSB 390	390			580 g
B123CrMo-SSB 400	400			590 g
B123CrMo-SSB 420	420			600 g

B123AA-SSB

MATERIAL / HEAT TREATED ALUMINUM
 CENTER DIA / 31.8
 BAR DIA / 23.8
 COLOR / SILVER ANODIZED

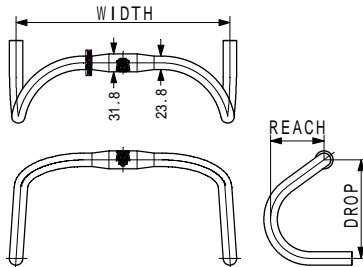

MODEL	WIDTH	DROP	REACH	WEIGHT
B123AA-SSB 370	370	175	95	340 g
B123AA-SSB 380	380			345 g
B123AA-SSB 390	390			350 g
B123AA-SSB 400	400			355 g
B123AA-SSB 420	420			360 g

S92

MATERIAL / FORGED ALUMINUM
 POST DIAM / 27.2mm
 OFFSET / 0 mm
 LENGTH / 250, 300, 350mm
 WEIGHT / 292, 322, 348 g
 (30.9 350mm 350 g)
 (31.6 350mm 350 g)
 COLOR / SILVER ANODIZED
 BLACK ANODIZED

*1)

この商品は、(一財)自転車産業振興協会が実施した平成28年度新商品・新技術研究開発事業により開発されたものです。



*1) Do not use a saddle with carbon fiber rails.
 This seat post is not compatible with them.

*1) カーボン製レールのサドルには、非対応です。

Clamp On UI-12

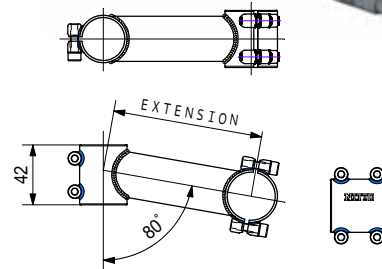

MATERIAL / CrMo
 BAR CLAMP / 31.8
 POST CLAMP / 28.6
 COLOR / SILVER

MODEL	EXTENSION	WEIGHT
Clamp On UI-12 - 60	60	190 g
Clamp On UI-12 - 70	70	195 g
Clamp On UI-12 - 80	80	205 g
Clamp On UI-12 - 90	90	215 g
Clamp On UI-12 - 100	100	225 g
Clamp On UI-12 - 110	110	235 g
Clamp On UI-12 - 120	120	245 g



Road Racing



M106 SSB(31.8)

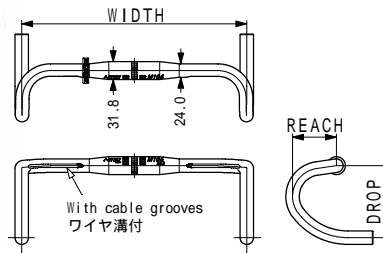

MATERIAL/HEAT TREATED ALUMINUM
 CENTER DIAM/ 31.8
 BAR DIAM/ 24.0
 COLOR/SILVER/BLACK ANODIZED

MODEL	WIDTH	DROP	REACH	WEIGHT
M106SSB-380	380	128	78	330 g
M106SSB-400	400			340 g
M106SSB-420	420			350 g



M106 NAS

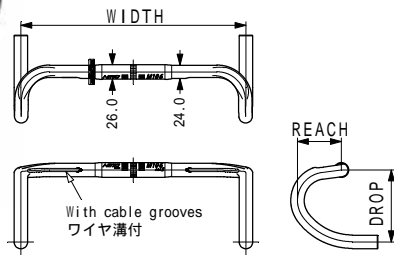

MATERIAL/HEAT TREATED ALUMINUM
 CENTER DIAM/ 26.0
 BAR DIAM/ 24.0
 COLOR/SILVER/BLACK ANODIZED

MODEL	WIDTH	DROP	REACH	WEIGHT
M106NAS-380	380	128	78	300 g
M106NAS-400	400			310 g
M106NAS-420	420			320 g



M186 STI

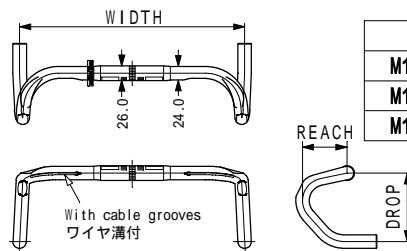

MATERIAL/HEAT TREATED ALUMINUM
 CENTER DIAM/ 26.0
 BAR DIAM/ 24.0
 COLOR/SILVER/BLACK ANODIZED

MODEL	WIDTH	DROP	REACH	WEIGHT
M186STI-380	380	122	80	300 g
M186STI-400	400			305 g
M186STI-420	420			310 g



M190Euro80

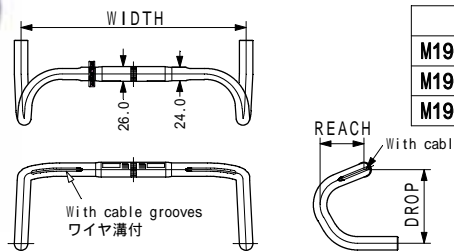

MATERIAL/HEAT TREATED ALUMINUM
 CENTER DIAM/ 26.0
 BAR DIAM/ 24.0
 COLOR/SILVER ANODIZED

MODEL	WIDTH	DROP	REACH	WEIGHT
M190Euro80-380	380	131	80	310 g
M190Euro80-400	400			315 g
M190Euro80-420	420			320 g

With cable grooves ワイヤ溝付
 With double cable grooves 前後ワイヤ溝付



M151AAF

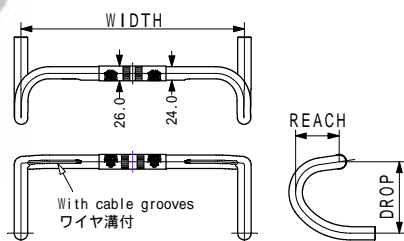

MATERIAL/ALUMINUM
 CENTER DIAM/ 26.0
 BAR DIAM/ 24.0
 COLOR/SILVER ANODIZED

MODEL	WIDTH	DROP	REACH	WEIGHT
M151AAF-380	380	128	78	325 g
M151AAF-400	400			330 g
M151AAF-420	420			335 g
M151AAF-440	440			365 g
M151AAF-460	460			370 g



Road Racing

B105AA-SSB(31.8)

MATERIAL / HEAT TREATED ALUMINUM
 CENTER DIAM / 31.8
 BAR DIAM / 23.8
 COLOR / SILVER
 BLACK ANODIZED

MODEL	WIDTH	DROP	REACH	WEIGHT
B105AA-SSB-400	400	135	95	360 g
B105AA-SSB-420	420			370 g
B105AA-SSB-440	440			380 g

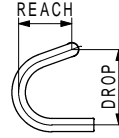
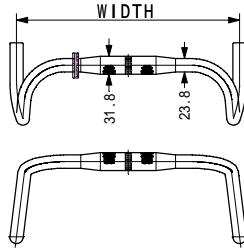

B105AA

MATERIAL / ALUMINUM
 CENTER DIAM / 25.4
 BAR DIAM / 23.8
 COLOR / SILVER ANODIZED

MODEL	WIDTH	DROP	REACH	WEIGHT
B105AA-370	370	135	95	300 g
B105AA-380	380			305 g
B105AA-390	390			310 g
B105AA-400	400			315 g
B105AA-410	410			320 g
B105AA-420	420			325 g

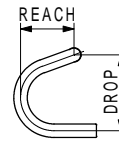
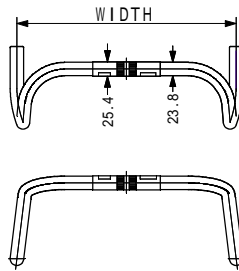

Neat Mod.185

MATERIAL / ALUMINUM
 CENTER DIAM / 26.0
 BAR DIAM / 24.0
 COLOR / SILVER ANODIZED

MODEL	WIDTH	DROP	REACH	WEIGHT
Neat Mod.185-380	380	140	82	330 g
Neat Mod.185-400	400			340 g
Neat Mod.185-420	420			350 g

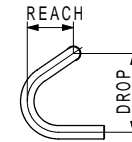
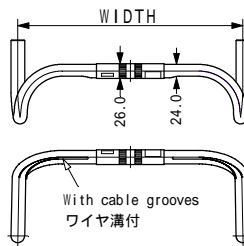

B115AA

MATERIAL / ALUMINUM
 CENTER DIAM / 25.4
 BAR DIAM / 23.8
 COLOR / SILVER ANODIZED

MODEL	WIDTH	DROP	REACH	WEIGHT
B115AA-380	380	140	100	315 g
B115AA-400	400			325 g
B115AA-420	420			335 g
B115AA-440	440			390 g
B115AA-450	450			395 g

